

# NJR Home Services General Terms and Conditions – All Plans

This is your official agreement with NJR Home Services (NJRHS) and provides a detailed description of the terms and conditions of our service contracts. To get the most from your coverage, we recommend that you become familiar with this information and retain this booklet for future reference.

**Important: Updates have been made to the terms and conditions of your service contracts. Please read and retain for your records.**

**EFFECTIVE MAY 2011.**

**ALL OTHER CONTRACTS ARE NULL AND VOID.  
PLAN SUBJECT TO CHANGE WITHOUT NOTICE.**

## GENERAL TERMS OF COVERAGE

### SERVICE TERRITORY

Service is limited to NJRHS' current territory. We reserve the right to refuse service based on location.

### SEPARATE CONTRACTS FOR EACH UNIT

If there is more than one natural gas furnace or boiler, electric central air conditioner or water heater in the residence, a separate residential service contract must be purchased for each unit you want covered.

If there is more than one of the same appliance and only one contract for that appliance type, the contract will apply to the equipment servicing the first floor or main living area.

### EFFECTIVE DATE

Your initial coverage officially takes effect at midnight on the 14th day following your oral or written commitment with NJRHS. The contract will end one year from the effective date. NJRHS will notify you in writing of your effective date. Contracts will renew automatically at the end of each one-year period.

### CANCELLATIONS

You may cancel your service contracts at any time for any reason. To cancel, please notify Customer Services at **877-466-3657**.

If you cancel within the first 30 days of coverage and you have not had a service call, you'll receive a full refund.

If you cancel after 30 days, **NO REFUNDS WILL BE GIVEN.**

### TERMINATION

NJRHS may terminate your service contracts with no refund in the event any one of the following occurs:

- Parts are no longer available from the original manufacturer, and there are no reasonably available alternate or interchangeable parts
- Removal of a defective part or the installation of a replacement part by someone other than an NJRHS employee results in damage to the appliance
- Removal of a piece of equipment by someone other than an NJRHS employee results in a safety hazard or an unsafe condition
- Equipment is not used for its designed purpose
- Failure by owner to properly maintain equipment or to replace any parts necessary to maintain the equipment in good condition, including cleaning or changing filters
- Repair costs would be greater than the original value of the equipment
- Service will not be provided and contracts can be cancelled if customer's account is not in good standing

NJRHS reserves the right to terminate service contracts for the failure of the owner to comply with provisions of this service contract.

### CHANGE OF ADDRESS

Coverage is not transferable to another address. However, if a contract was paid in full for equipment that remains in operation at the premises, the unexpired term of coverage will be applied to the new owner/occupant of the premises at no additional charge. If a contract has not been paid in full, you will be billed for the remaining payments.

If you move, call Customer Services at **877-466-3657** to cover the appliances in your new home.

If you choose the monthly payment option and decide to cancel before the end of the term, you will be billed for the remaining payments.

If you are selling your home, notify your realtor and closing agent. You may be able to recover costs.

### RENEWAL

For your convenience and to ensure that your home is continuously covered, contracts will renew automatically at the end of each one-year period. NJRHS reserves the right to change the terms and conditions at any time and to change the contract price upon contract renewal.

## CHOICE OF PAYMENT OPTIONS

If you are a residential customer of New Jersey Natural Gas (NJNG), you may pay for coverage in full or make equal payments over a 6- or 12-month period. If you choose to pay on a monthly basis, the charge will appear on your regular monthly NJNG bill. Service contract coverage is for a full 12-month period. If you choose the monthly payment option and decide to cancel before the end of the term, you will be billed for the remaining payments.

Non-NJNG customers and owners who do not occupy the covered residence (landlords) are not eligible for the monthly payment option. Payment in full must be provided prior to coverage.

## MISSED PAYMENTS

If payments are missed or late, NJRHS may demand immediate payment of the entire amount owed or immediate payment of costs (labor and parts) for all services provided, less any payments made to NJRHS. Service will not be provided and contracts can be cancelled if a customer's account is not in good standing.

## ELIGIBILITY REQUIREMENTS OF ALL EQUIPMENT

• All covered equipment must conform to the requirements of the American National Standards Institute; be installed in accordance with local, state and federal codes; and satisfy both the manufacturer's and NJRHS' requirements for safe and proper installation.

• Before accepting any equipment for coverage under the service contracts, NJRHS reserves the right to make an on-site inspection of the equipment.

• To be eligible for coverage under the service contracts, equipment must be warranted by the owner to be in good operating condition, duly assembled and capable of functioning on the service contract's effective date.

• NJRHS reserves the right to deny or cancel coverage for certain equipment due to the non-availability of parts, inaccessibility, the condition of the equipment or worksite, damage by a third party or the age of the equipment.

## CONDITIONS OF COVERAGE

• NJRHS strives to render prompt, efficient and courteous service. Our response time will be determined by scheduling appointments that consider public safety, existing workloads, the nature of the service call and weather conditions.

• Work must be performed by NJRHS technicians. You will not receive credit or reimbursement for work performed, or parts installed, by other service providers under any circumstances.

• All parts under warranty replaced by an NJRHS technician become the property of NJRHS without any allowance or rebate at the discretion of NJRHS. If NJRHS chooses not to take possession of the parts, it becomes the customer's responsibility to dispose of them properly.

• NJRHS may use universal parts to repair your equipment.

• **Customers must supply safe and ready access to all covered equipment**, including but not limited to OSHA-approved ladders, adequate attic flooring and proper lighting and entry. NJRHS is not responsible for damage to attic ladders as a result of normal use. For safety reasons, your appliance will not be serviced if it is surrounded by standing water or it is located outside and weather conditions make service unsafe.

• If in the process of repairing a covered part, noncovered parts are needed to complete the repair, the customer will be charged for the cost of the noncovered parts and our standard labor rate.

• If a part which is covered under the heat service contract is replaced while in use as part of an electric central air conditioning system and the customer does not have an air conditioning service contract with NJRHS, the part will be replaced at no charge on the condition that the customer agrees to pay the standard labor rate for the air conditioning service call.

## GENERAL EXCLUSIONS

The following items are excluded from contract coverage but may be available for an additional charge:

• Appearance and trim parts, and upgraded components, such as humidifiers and electronic air filters

• Appliance shut-off valves, piping, flex connectors and fittings external to unit (unless Internal Natural Gas Line Service Contract is in effect)

• Cleaning soot out of, and off of, appliances and flues

• Damage caused by misuse, abuse, vandalism, negligence, fire, freezing, power or water supply outages, flooding, faulty design, improper installation, leaks from piping, humidifiers, lightning, power surges, acts of God and other conditions beyond control of NJRHS.

• Damage due to failure to maintain equipment

• Facilities used for commercial purposes

• Finish defects, rusting, corrosion, chipped porcelain or porcelain flaws, exterior housing or component failure resulting from rust or corrosion on any appliance or piece of equipment

• Heat exchangers and compressors

• Materials and labor for any service that is additional to that specified in the service contract, such as sheet metal work, electrical house wiring, moving or relocating equipment

• Mold cleanup or remediation

• Pre-existing conditions, which include anything that was wrong with your appliance at the time you signed up for the service contract

• Preventive maintenance and general inspection (unless equipment is covered by a Premier contract)

• Seasonal startups (extra charges apply)

• Service will not be provided and contracts can be cancelled if customer's account is not in good standing.

• Unit replacements

• Water filters or water filtration equipment

• Water storage tanks

## ADDITIONAL CHARGES

• Replacement of standard batteries is not covered, but may be provided for an additional charge.

• Parts not covered in this contract may be ordered and installed by NJRHS, when available, for an additional charge at our standard repair rates.

• If the water heater manufacturer recommends replacement of unit after flammable vapor ignition resistance (FVIR) system fails, the water heater will be deemed not repairable.

## EXCLUSION OF WARRANTIES AND LIMITATIONS ON DAMAGES

NJRHS WARRANTS THAT, SUBJECT TO THE TERMS AND CONDITIONS STATED HEREIN, NJRHS WILL REPAIR OR REPLACE THE APPLIANCE PARTS, OR EQUIPMENT COMPONENT PARTS COVERED UNDER THE SERVICE CONTRACT, THAT BECOME INOPERABLE AS A RESULT OF NORMAL WEAR AND TEAR.

**NJRHS MAKES NO OTHER EXPRESS OR IMPLIED WARRANTIES OR GUARANTEES OF ANY KIND. ANY IMPLIED WARRANTIES OR GUARANTEES ARE EXPRESSLY DISCLAIMED. UNDER NO CIRCUMSTANCES SHALL NJRHS BE LIABLE FOR ANY LOSSES OR DAMAGES OF ANY KIND RESULTING FROM THE FAILURE OR INOPERABILITY OF EQUIPMENT OR SYSTEMS IN EXCESS OF THE PAYMENT RECEIVED BY NJRHS UNDER THIS AGREEMENT.**

NJRHS ALSO SHALL NOT BE LIABLE FOR ANY DAMAGES OR HARM TO PERSONS OR PROPERTY CAUSED BY DELAYS, FAILURE TO SERVICE, MALFUNCTIONING OF THE EQUIPMENT, UNAVAILABILITY OF PARTS, LABOR DIFFICULTIES, ACTS OF NATURE OR OTHER CONDITIONS BEYOND ITS CONTROL.

## IMPORTANT SAFETY INFORMATION

### Natural gas emergencies include:

- A strong odor of natural gas inside or outside your home
- A natural gas appliance that will not shut off
- Suspicion of a carbon monoxide leak

### What to Do During a Natural Gas Emergency

If you are facing any of these situations, don't wait! Take the following action immediately:

• **MOVE** to a safe environment.

• **CALL** 911 and your local natural gas utility (not NJRHS) at once to report the natural gas emergency.

• **DO NOT** smoke or operate electrical switches or appliances of any kind. Do not operate anything that may produce a spark that might ignite the natural gas and cause an explosion.

Natural gas appliances should always be operated and maintained according to the manufacturer's instructions.

Always take the time to become familiar with the instructions – especially safety warnings.

# NJR Home Services Premier Comfort Service Plans

## RESIDENTIAL NATURAL GAS

### BOILER/FURNACE PARTS COVERED:

- Annual Inspection (one per year)
- Aquastat (dry well)
- Automatic air vents†
- Belt and pulley
- Blower motor/blower wheel (labor not covered June 1 - August 31)\*
- Burners
- Circulator pump\*\*\*\*†
- Circuit board/ignition control
- Condensate pump on a condensating furnace
- Drain valves†
- Emergency switch
- Expansion tank (bladder type only)†
- Fan and limit control
- Flushing boiler water, cleaning sight glass, bleeding air from radiators and hydronic heating systems†
- Gas valve
- Ignition system
- Inducer motor and assembly (original part only, excludes sidewall venting kits)\*\*
- Internal wiring
- Limit controls
- Low-water cutoffs†
- Pilot assembly/ignitor
- Pressure relief valve†
- Pressure temp gauge†
- Pressure switch
- Pressuretrol/pigtail assembly†
- Relay
- Thermocouple
- Thermopile
- Thermostat (truck stock, non-mercury only)\*\*\*
- Thermostat backplate
- Transformer
- Vent damper (original equipment only)
- Zone valve head\*\*

\*If a replacement is unavailable, and if feasible, the motor will be rebuilt.

\*\*Parts not covered can be replaced by NJRHS at standard repair rates.

\*\*\* Customers who wish to upgrade a thermostat may do so at an additional fee.

\*\*\*\* One circulator pump and assembly per boiler.

† Work will only be covered under the contract if there is a backflow preventer currently installed. If there is no backflow preventer you must have one installed for an additional fee at normal rates. Any work requiring soldering of parts to be repaired or installed is not covered under the contract. NJRHS is not responsible for the backflow preventer or water pressure reducing valve once the boiler is drained, or any water leaks that might occur during the course of the repair. Circulator pumps, flanges, bronze pumps and basement loops off of a steam boiler system are not covered. These boiler parts are covered under the **Premier Heating Plan** and the **Premier Heating and Cooling Plan**. These parts are not covered under the standard Heating Service Contract.

### BOILER/FURNACE EXCLUSIONS:

- Accessory components, such as humidifiers, electronic air filters and zone dampers
- Any batteries, whether standard or hardwired
- Anything in the potable water system
- Circuit breakers and external wiring
- Cleaning and replacing air filters
- Domestic hot water coil
- Expansion tank (ceiling mounted)
- Flues, piping and heat exchangers
- Heat transfer fluid (antifreeze)
- Natural gas house-heating units rated at inputs above 400,000 British thermal units (Btus)
- Natural gas house-heating units serving more than a two-family residence
- Soot removal and descaling of high-efficiency systems
- Tjerlund, flair, other sidewall venting kits, motors and assemblies
- **Does not include replacement of unit**

### DOMESTIC HOT WATER HEATER\* PARTS COVERED:

#### Residential Natural Gas/Electric Water Heater

- Access door gasket
- Burner (atmospheric)
- Drain valves
- Emergency cutoff safety control
- Heating element
- Internal wiring
- Manufacturer installed power vents
- Piezo ignitor
- Pilot and assembly

- Pressure temperature relief valve (must have shut-off valve on cold water intake)
- Switching relay
- Temperature control and thermostat
- Thermocouple
- Transformer

### DOMESTIC HOT WATER HEATER\* EXCLUSIONS:

- After market power vents
- Anodes
- Battery/backup
- Circulator pump
- Cleaning and replacing air filters
- Cleaning FVIR screen
- Dip tubes
- Electric water heating units rated above 240 volts
- Flue pipe
- FVIR system
- Housing piping and shut-off valves
- Natural gas water heating units rated at 80,000 Btus or more
- Timers
- Units over 75 gallons
- Water heater tank failure or leakage
- Water heating units serving more than a two-family residence
- Wiring and circuit breaker to electric water heater
- **Does not include replacement of unit**

\* Tankless, on-demand and power-vented water heaters are not covered under the standard water heater contract. Customers must upgrade to the Tankless/On-Demand/Power-Vented Water Heater Contract to be covered.

### RESIDENTIAL TANKLESS/ON-DEMAND/POWER-VENTED DOMESTIC WATER HEATER PARTS COVERED:

- Burner
- Circuit board (PCB)
- Combustion fan
- Condensate pump
- Ignitor
- Inducer motor
- Internal water screen
- Overheat switch
- Spark electrode
- Surge protector
- Thermal fuse
- Thermistors
- Water flow control device (exterior models)
- Water flow sensor

### TANKLESS/ON-DEMAND/POWER-VENTED DOMESTIC WATER HEATER EXCLUSIONS:

- Electric water heating units rated above 240 volts
- Flue pipe
- Flushing and descaling of high-efficiency water heating systems
- Heat exchanger
- Mixing valve
- Water heating units rated above 250,000 Btus
- Natural gas water heating units serving more than two-family residence
- Wiring to electric water heater (line voltage)
- **Does not include replacement of unit**

### INDIRECT HOT WATER STORAGE TANK PARTS COVERED\*:

- Circulator motor, if separate from boiler
- Non-factory installed parts and controls\*\*
- Relay
- Relief valve
- Thermostat
- Zone valve motor or head

### INDIRECT HOT WATER STORAGE TANK PARTS EXCLUSIONS\*:

- Flow valves
- Gaskets
- Heat exchanger and coil
- **Does not include replacement of unit**

\* Must have separate Heating and Water Heater Service Contract.

\*\* Including but not limited to recirculating pumps and storage tanks

### RESIDENTIAL CENTRAL AIR CONDITIONER/HEAT PUMPS PARTS COVERED:

- Annual inspection (one per contract year)
- Belts
- Blower motor (June 1 - August 31 only)
- Circuit boards
- Clean and repair condensate line (only if line is visible and accessible)

- Condenser fan motor/blade
- Condensate pump
- Contactor
- Defrost cycle relay (heat pump)
- External crankcase heater
- Fuse (cartridge type)
- Low ambient temperature control (only if installed)
- Low-voltage wiring (only if wiring is exposed and accessible)
- Motor speed control
- Refrigerant (up to 2 lbs.)\*
- Relays
- Run capacitor
- Start capacitor
- Thermostat\*\*
- Time delay controls
- Transformers
- Wet switch (only if installed)

\* If unit needs refrigerant added more than once, subsequent injecting will be completed only after a thorough leak investigation at NJRHS rates.

\*\* Customers who wish to upgrade a thermostat may do so at an additional fee.

### CENTRAL AIR CONDITIONER/HEAT PUMP EXCLUSIONS:

- Any repairs that require accessing the refrigerant system, including leak investigation, leak repairs, internal blockages and all internal component replacements
- Cleaning evaporator coil
- Compressors
- Condenser or evaporator coils
- Disconnect, circuit breaker or electrical wire
- Drain pans – primary and secondary
- Refrigerant piping (line sets)
- Residential air conditioners/heat pumps above five tons
- **Does not include replacement of unit**

Note: Outside temperatures below 65 degrees, excessive attic temperatures and/or inclement weather may prevent the completion of air conditioning repairs until conditions permit.

### ANNUAL INSPECTIONS

It is the customer's responsibility to call NJRHS to schedule the annual inspections.

Scheduling of inspections during peak months will be restricted based on volume of no heat and no air conditioning work. We will not perform any inspections between October 1 - December 31.

It is the customer's responsibility to clean or change the filter regularly during the year.

### HEATING INSPECTIONS

**Steam Boiler, Hot Water Boiler, Warm Air Furnace**  
Also includes an inspection of your Hot Water Heater

- Check safeties and controls; adjust (if necessary)
- Check/adjust thermostat(s)
- Check/clean burners
- Check/clean pilot/pilot sensor
- Check/clean gauge glass and flush low-water cutoff
- Check filter(s) and belts (if applicable)
- Check flue pipe and check chimney draft
- Oil motors and pumps (if necessary)
- Check blower assembly (furnace) and clean
- Check condensate line for blockage (90% efficiency and above)

### WATER HEATER

- Check thermostat and burner operation
- Check flue and check chimney draft
- Check for water leaks
- Check for piping corrosion
- Check age and condition

### AIR CONDITIONING INSPECTIONS

- Check/adjust thermostat(s)
- Clean condenser coil (where necessary)
- Check and clean condensate lines (only if line is visible and accessible)
- Check starting and running amps on compressor
- Visual inspection for refrigerant leaks
- Check contactors and relays
- Inspect all electrical connections (as necessary)
- Check filter(s)
- Check emergency disconnect
- Check operating pressures
- Visually inspect internal condensate pan
- Visually inspect emergency condensate pan (where applicable)

# NJR Home Services Basic Service Plans

## RESIDENTIAL NATURAL GAS

### BOILER/FURNACE PARTS COVERED:

- Aquastat (dry well)
- Belt and pulley
- Blower motor/blower wheel (labor not covered June 1 - August 31)\*
- Burners
- Circuit board/ignition control
- Condensate pump on a condensating furnace
- Emergency switch
- Fan and limit control
- Gas valve
- Ignition system
- Inducer motor and assembly (original part only, excludes sidewall venting kits)\*\*
- Internal wiring
- Limit controls
- Pilot assembly/ignitor
- Pressure relief valve†
- Pressure switch
- Relay
- Thermocouple
- Thermopile
- Thermostat (truck stock, non-mercury only) \*\*\*
- Thermostat backplate
- Transformer
- Vent damper (original equipment only)
- Zone valve head\*\*

\*If a replacement is unavailable, and if feasible, the motor will be rebuilt.

\*\*Parts not covered can be replaced by NJRHS at standard repair rates.

\*\*\* Customers who wish to upgrade a thermostat may do so at an additional fee.

\*\*\*\* One circulator pump and assembly per boiler.

† Work will only be covered under the contract if there is a backflow preventer currently installed. If there is no backflow preventer you must have one installed for an additional fee at normal rates. Any work requiring soldering of parts to be repaired or installed is not covered under the contract. NJRHS is not responsible for the backflow preventer or water pressure reducing valve once the boiler is drained, or any water leaks that might occur during the course of the repair. Circulator pumps, flanges, bronze pumps and basement loops off of a steam boiler system are not covered.

### BOILER/FURNACE EXCLUSIONS:

- Accessory components, such as humidifiers, electronic air filters and zone dampers
- Annual inspections or preventive maintenance.
- Any batteries, whether standard or hardwired
- Anything in the potable water system
- Circuit breakers and external wiring
- Cleaning and replacing air filters
- Domestic hot water coil
- Expansion tank
- Flues, piping and heat exchangers
- Heat transfer fluid (anti-freeze)
- Natural gas house-heating units rated at inputs above 400,000 Btus
- Natural gas house-heating units serving more than a two-family residence
- Soot removal and descaling of high-efficiency systems
- Tjerlund, flair, other sidewall venting kits, motors and assemblies
- **Does not include replacement of unit**

### DOMESTIC HOT WATER HEATER\* PARTS COVERED:

#### Residential Natural Gas/Electric Water Heater

- Access door gasket
- Burner (atmospheric)
- Drain valves
- Emergency cutoff safety control
- Heating element
- Internal wiring
- Manufacturer installed power vents
- Piezo ignitor
- Pilot and assembly
- Pressure temperature relief valve (must have shut-off valve on cold water intake)
- Switching relay
- Temperature control and thermostat
- Thermocouple
- Transformer

### DOMESTIC HOT WATER HEATER\* EXCLUSIONS:

- After market power vents
- Anodes

- Battery/backup
- Circulator pump
- Cleaning and replacing air filters
- Cleaning FVIR screen
- Dip tubes
- Electric water heating units rated above 240 volts
- Flue pipe
- FVIR system
- Housing piping and shut-off valves
- Natural gas water heating units rated at 80,000 Btus or more
- Timers
- Units over 75 gallons
- Water heater tank failure or leakage
- Water heating units serving more than a two-family residence
- Wiring and circuit breaker to electric water heater
- **Does not include replacement of unit**

\* Tankless, on-demand and power-vented water heaters are not covered under the standard water heater contract. Customers must upgrade to the Tankless/On-Demand/Power-Vented Water Heater Contract to be covered.

### RESIDENTIAL TANKLESS/ON-DEMAND/POWER-VENTED DOMESTIC WATER HEATER PARTS COVERED:

- Burner
- Circuit board (PCB)
- Combustion fan
- Condensate pump
- Ignitor
- Inducer motor
- Internal water screen
- Overheat switch
- Spark electrode
- Surge protector
- Thermal fuse
- Thermistors
- Water flow control device (exterior models)
- Water flow sensor

### TANKLESS/ON-DEMAND/POWER-VENTED DOMESTIC WATER HEATER EXCLUSIONS:

- Electric water heating units rated above 240 volts
- Flue pipe
- Flushing and descaling of high-efficiency water heating systems
- Heat exchanger
- Mixing valve
- Water heating units rated above 250,000 Btus
- Natural gas water heating units serving more than two-family residence
- Wiring to electric water heater (line voltage)
- **Does not include replacement of unit**

### RESIDENTIAL INDIRECT HOT WATER STORAGE TANK PARTS COVERED\*:

- Circulator motor, if separate from boiler
- Relay
- Relief valve
- Thermostat
- Zone valve motor or head

### INDIRECT HOT WATER STORAGE TANK PARTS EXCLUSIONS\*:

- Flow valves
- Gaskets
- Heat exchanger and coil
- **Does not include replacement of unit**

\* Must have separate Heating and Water Heater Service Contract.

### RESIDENTIAL CENTRAL AIR CONDITIONER/HEAT PUMPS PARTS COVERED:

- Belts
- Blower motor (June 1 - August 31 only)
- Circuit boards
- Clean and repair condensate line (only if line is visible and accessible)
- Condenser fan motor/blade
- Condensate pump
- Contactor
- Defrost cycle relay (heat pump)
- External crankcase heater
- Fuse (cartridge type)
- Low ambient temperature control (only if installed)
- Low-voltage wiring (only if wiring is exposed and accessible)
- Motor speed control
- Refrigerant (up to 2 lbs.)\*

- Relays
- Run capacitor
- Start capacitor
- Thermostat\*\*
- Time delay controls
- Transformers
- Wet switch (only if installed)

\* If unit needs refrigerant added more than once, subsequent injecting will be completed only after a thorough leak investigation at NJRHS rates.

\*\* Customers who wish to upgrade a thermostat may do so at an additional fee.

### CENTRAL AIR CONDITIONER/HEAT PUMP EXCLUSIONS:

- Any repairs that require accessing the refrigerant system, including leak investigation, leak repairs, internal blockages and all internal component replacements
- Annual inspections or preventive maintenance.
- Cleaning evaporator coil
- Compressors
- Condenser or evaporator coils
- Disconnect, circuit breaker or electrical wire
- Drain pans – primary and secondary
- Refrigerant piping (line sets)
- Residential air conditioners/heat pumps above five tons
- **Does not include replacement of unit**

Note: Outside temperatures below 65 degrees, excessive attic temperatures and/or inclement weather may prevent the completion of air conditioning repairs until conditions permit.

### RESIDENTIAL INTERNAL NATURAL GAS LINE PARTS COVERED:

- Black and/or galvanized piping from 1/2" to 1 1/2" diameter in size
- Includes 1/2" and 3/4" shut-off valves (leaking or inoperable only)
- Replacement of flexible connectors on hot water heater and furnace, if completely accessible (replacement only if leaking or as needed)
- Leaks in crawl spaces and attics on exposed pipe, if accessible
- Repairs are limited to \$2,500 maximum per year

### INTERNAL NATURAL GAS LINE EXCLUSIONS:

- Any piping not up to code
- B valves
- Damage caused by third parties or natural disasters
- Facilities used for commercial purposes
- Manufactured homes and trailers
- Natural gas meters
- New construction covered under warranty
- Nothing outside the home is covered – including any appliances inside detached garages
- Permit fees (customers pay)
- Repairs to fuel lines supplying yard lights, grills and pool heaters
- Restoration to affected areas
- Services such as connecting or disconnecting appliances
- Unexposed pipe
- Ventless fireplace valves or piping to a fireplace

These diagrams highlight the typical location of certain parts in heating, ventilation, air conditioning and water heating equipment. These diagrams are not intended to, and do not, indicate whether a particular part is covered under any NJRHS service contract.

### Furnace

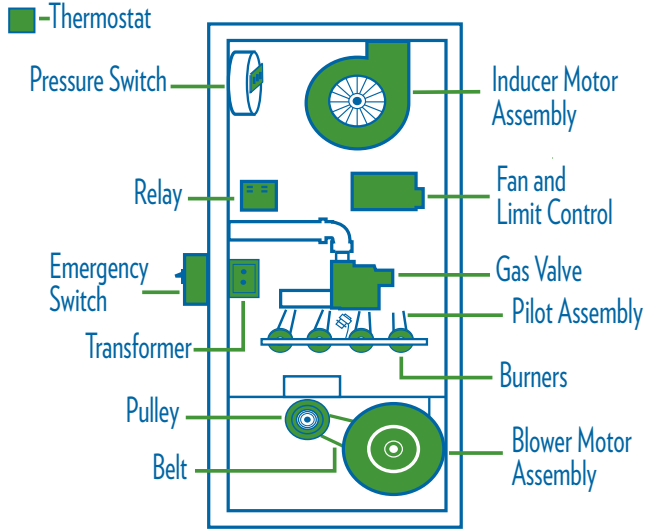

### Boiler

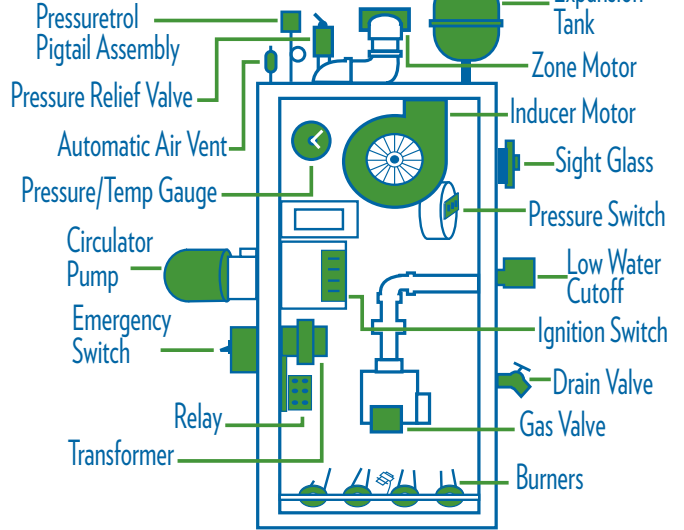

### Natural Gas Hot Water Heater

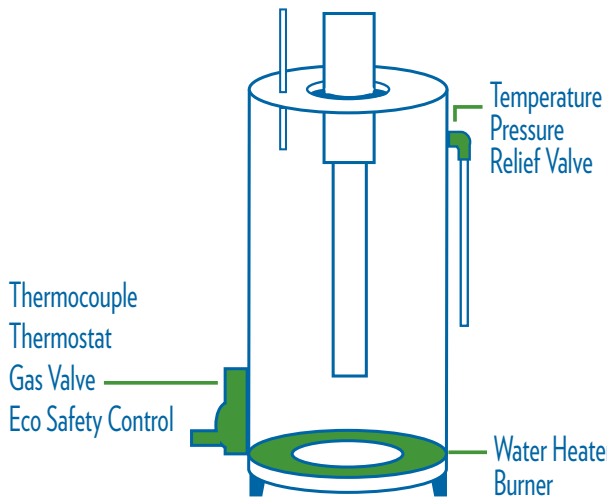

### Electric Water Heater

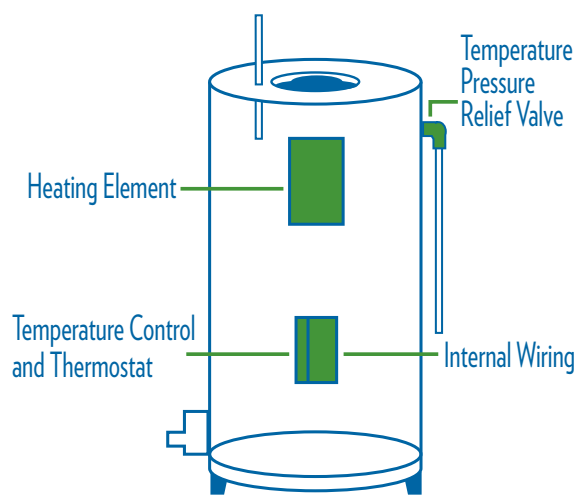

### Tankless Water Heater

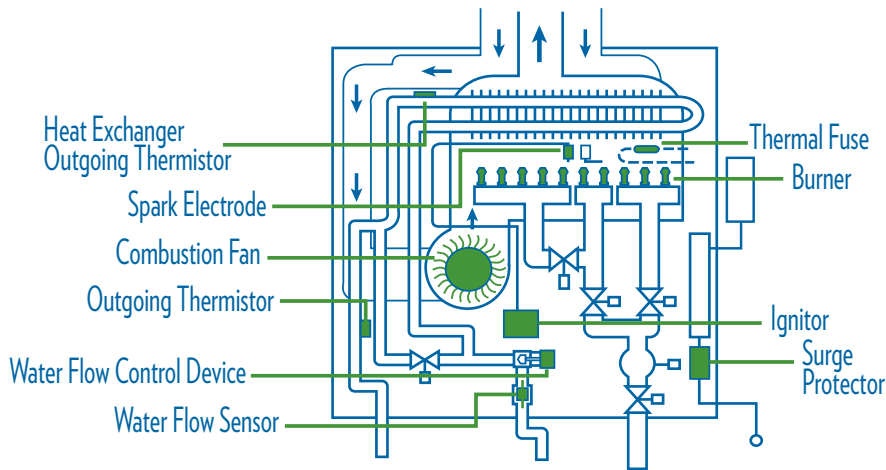

### Central Air Conditioner

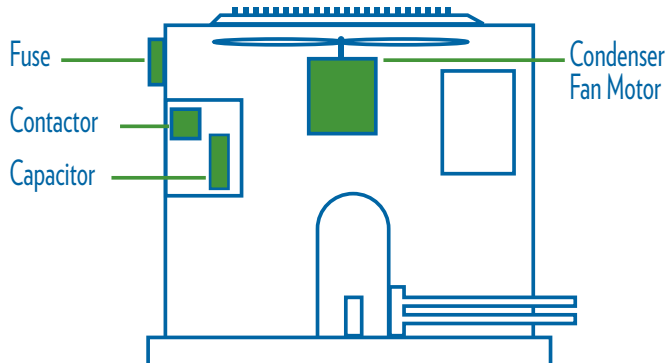

### Internal Natural Gas Line

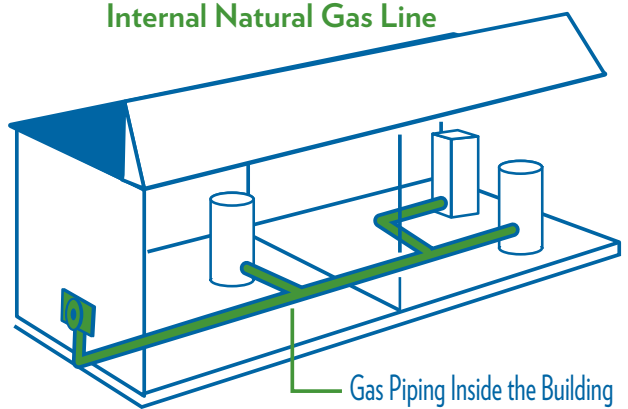

All work required by law to be performed by a licensed master plumber or authorized plumbing contractor will be performed not by NJR Home Services, but by a separate entity authorized to act as a plumbing contractor pursuant to the State Plumbing License Law of 1968 and the regulations promulgated by the State Board of Examiners of Master Plumbers.

NJR Home Services is not the same company as New Jersey Natural Gas, the utility, and is not regulated by the New Jersey Board of Public Utilities. You do not have to buy products or services from NJR Home Services in order to continue receiving regulated services from New Jersey Natural Gas.

